



Tapecoat Handwrapster

The Handwrapster tool is designed to assist the operator in keeping the correct overlap and tension when applying Tapecoat cold-applied tapes.



Handwrapster Instructions

1. From the chart select the size of tape required for the particular size of pipe to be wrapped.
2. Adjust center shaft (7) according to the size tape needed and lock in place with wing nut (8). NOTE: The Tape Width Chart below shows maximum tape widths for certain sizes of pipe with a single layer applied. Smaller width rolls may be take longer.
3. As pipe size increases, move wheels (15) farther apart so they grasp the pipe as much as possible. Wing nuts (14) are provided to lock wheel axles so they don't twist out. NOTE: one wheel needs a spacer to clear adjustment plate (9).
4. Adapter plate is bolted to right wing in the two closest holes and wheels transferred to the holes in the plate. The purpose of the plate is to lift the right wing of the Wrapster in increasing the angle between it and the pipe. It allows for wider tape sizes on pipes smaller than 12", as shown in the chart. NOTE: It should always be used on 2" pipe.
5. The tape is placed on the Wrapster so that the tape comes off the top of the roll in a direction going away from the handle (12). This places tension knob (4) on operator's left.
6. The tape is fastened to the pipe with enough tension that the machine will not move by itself. Tension is increased or decreased simply by tightening or loosening knob (4) against tension spring (6).
7. The release liner separating layers of tape can be used to help wrap the pipe. Grasp the release liner after fastening the tape to the pipe. Pull the release liner toward the operator and over the handle (12). The liner should be pulled downward and used to rotate the machine around the pipe. Always pull the liner toward the pipe to keep the machine tight to the pipe. Rotate the machine downward using the liner, then grab the liner from the opposite side as it comes around the pipe and pull upward.
8. After a couple of wraps check for overlap desired. To increase lap, loosen knob (10) tightening the carriage bolt in the slot (11) that places the two wings closer to parallel position (in a completely parallel position there will be no travel and it will continue to wrap over itself.) To decrease lap, move carriage bolt to a lower position (toward wheels). This increases the angle between wings giving more spiral action down the pipe.
9. Double-wrapping can be done two different ways: either by just going over the pipe twice or setting the Wrapster for 1/2 as much travel. NOTE: When double wrapping, you may use wider tape than the chart suggests, i.e., 2" pipe may be double wrapped using 4" tape.
10. Changing tape -- remove tension knob (4), loosen handle (12) then pull the roll off and replace tape making sure tape is put on correctly. NOTE: Wrapster #3 may be used to wrap joints, short radius bends or lengths of any size pipe. It will also wrap vertically which will make it an asset in plant applications.

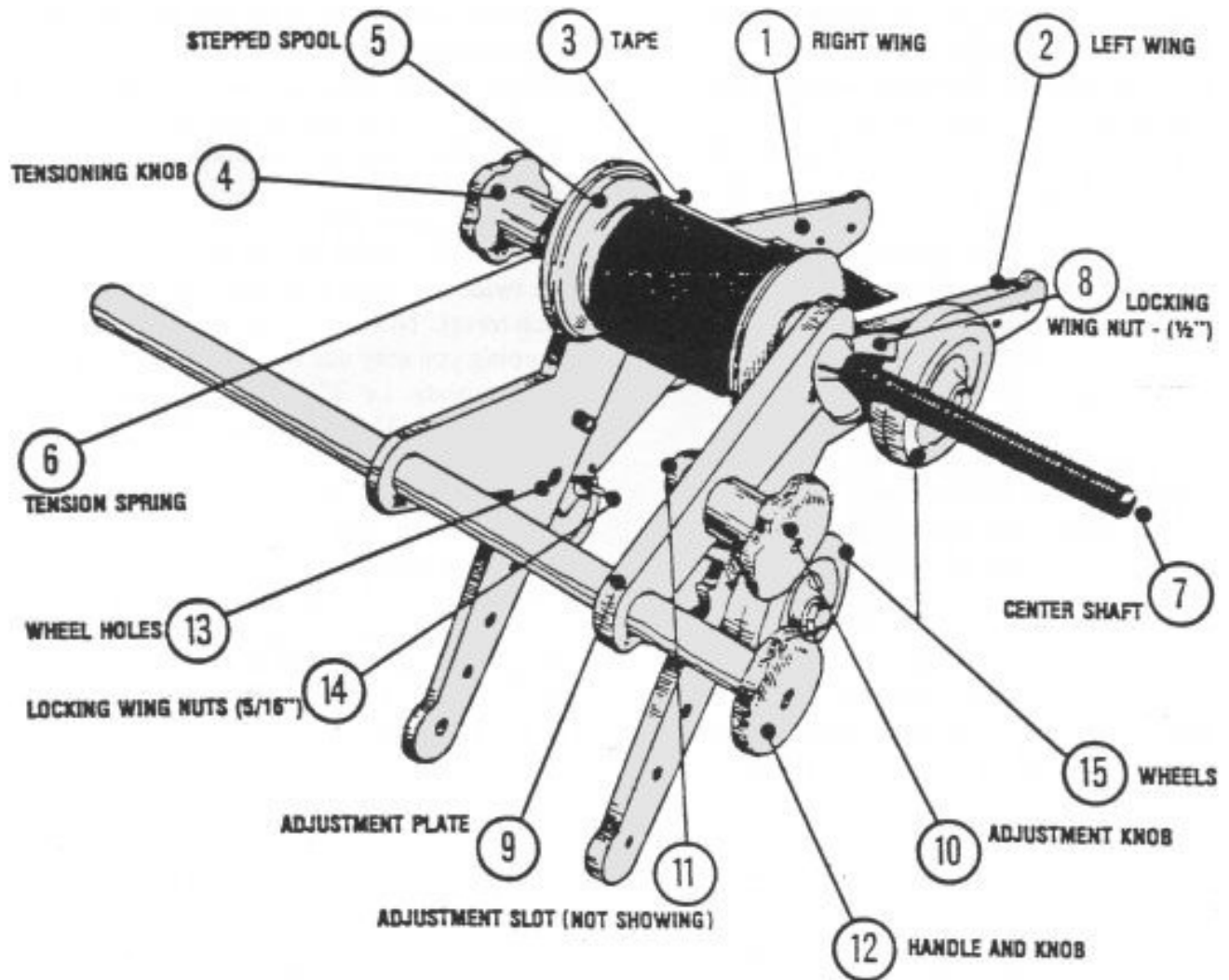

Without adapter plate	With adapter plate
no 2" pipe	2" pipe - 2" tape
3" pipe - 2" tape	3" pipe - 4" tape
4" pipe - 2" tape	4" pipe - 4" tape
6" pipe - 4" tape	6" pipe - 4" tape
8" pipe - 4" tape	8" pipe - 6" tape
10" pipe - 4" tape	10" pipe - 6" tape
12" pipe - 4" tape	10" pipe - 6" tape
24"-100" pipe - 6" or 9" tape	Not used for piper larger than 12"