



Orbital Forged Aluminum & Bronze Concrete Markers

These markers are manufactured of orbital forged aluminum, or bronze, to ensure that they will not crack, chip, or break. Both styles can be installed by tapping them into wet concrete or epoxy. The RC1 model is 2" in diameter. The RC02 model is 3 1/2" in diameter. Orbital Forged Aluminum & Bronze Concrete Markers can be stamped with a custom legend. See the artwork requirements page or go to www.RhinoMarkers.com.

Both aluminum and bronze concrete markers are long lasting and can be stamped in the field. The economical aluminum concrete markers can be used in low traffic or out of the way areas that are not exposed to salt. The bronze concrete marker works best in high traffic areas, areas exposed to salt in the winter and marine salt water environments.

Related Products

Anchoring Cement sets quickly and is easy to use. 2" Countersink Drill Bit allows you to drill the hole and countersink at the same time.

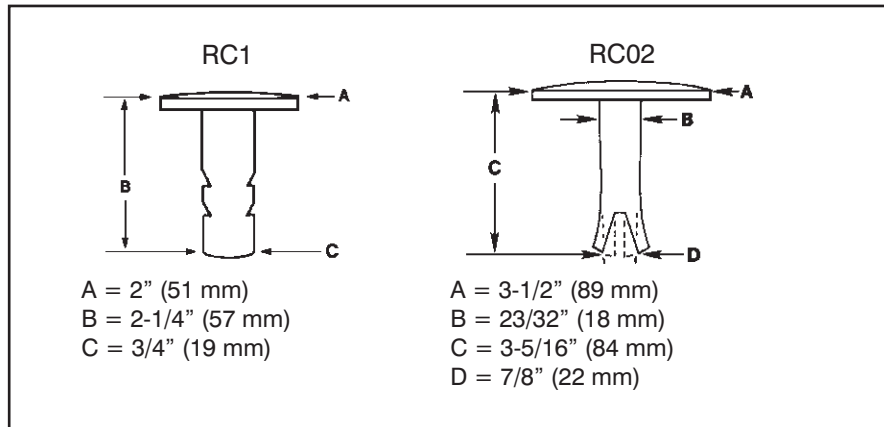

Custom examples